

The background of the page is a dark, grayscale photograph of an industrial workshop. In the foreground, several large hydraulic press brakes are visible, arranged in rows. The machines have long, flat beds and vertical columns. In the background, there are more industrial structures, possibly storage racks or parts of a production line, and a bright light source on the right side, creating a strong contrast and highlighting some of the machinery.

EUROMASTER-S
Hydraulic Press Brakes

EuroMaster-S

The EuroMaster-S is a press brake suited for series production. Its standard equipment and various options make the EuroMaster-S productive and reliable. The thicknesses and materials used ensure that the frame with gap in the side sections is designed to be extremely rigid. The machine is entirely manufactured in HACO group factories in Europe.

Intuitive FASTBEND Multi Touch control

EuroMaster-S comes standard with the intuitive FASTBEND-2D MT control. The Multi Touch technology application reduces the number of keyboard and button actions to an absolute minimum. The innovative Smart Draft, Design/Bending Sequence Multitasking, Step Previewer, Combined Icons and Auto Tooling features provide simple, intuitive control of the entire production cycle

It has been specially developed to make the machine accessible to everyone. The control is entirely developed and manufactured by HACO.

Top tooling

EuroMaster-S offers a large number of different top tool clamping types to best adapt to your products and production. Divided into two families: the European clamping system, named 'ES', and the New Standard clamping system, named 'NS'.

Sheet metal support

Sheet metal supports facilitate handling and reduce the physical strain for the operator. Adjustment is simplified thanks to the guides and the quarter-turn clamping system. Motorized sheet following devices are optional.

Table

The table of the EuroMaster-S allows you to accommodate a wide variety of bottom tools from the 'ES' & 'NS' ranges. The alignment system and its motorized crowning device allow for time savings and optimal precision.



Backgauge

The motorized backgauge minimizes adjustment times to the bare minimum. The fingers have 3 contact/support surfaces to adapt to different shapes of workpieces and to ensure stable positioning.

Safety

The machine has various components to ensure the users' safety.

Optical Safety Guard

Safety lasers ensure the safety of the operator while also allowing for an increase in the descent speed of the beam, thus enhancing productivity.

Advantages:

- Frame made of rigid, high-thickness welded steel.
- Large opening and stroke for optimized user comfort.
- Very wide variety of choices with more than thirty models of different lengths and powers.
- Ergonomic and contemporary design.
- Movement of the different axes at a very high speed.
- Simple and intuitive to use.

FASTBEND MT Control

Standard equipment

The FASTBEND-2D MT Control on 21.5" screen from HACO is the most efficient control unit available. It allows for simple and quick programming of 2D workpieces. After drawing your workpiece, the control automatically generates a bending sequence as well as the position of the various axes, making your machine easy and quick to program. The FASTBEND-2D MT Control can execute 3D programs thanks to the HACO BEND Pro offline programming software.

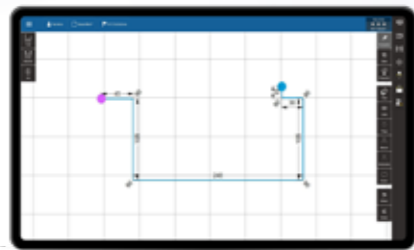

You can easily draw your workpiece in two different ways: the Point-to-Point method and the Smart Draft method

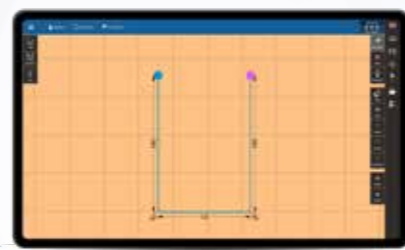

Automatic collision detection during the drawing phase.



Automatically defined bending sequence. For each step, the control unit calculates the positions of each axis.



Production: correction input, backgauge retraction, management of the top dead center, speed of the axes, etc...

Advantages:

- User-friendly and illustrated programming making the control accessible to everyone.
- High precision, flexibility & reliability for optimal performance.
- Ability to execute 3D programs with a 2D CNC.

Optional equipment

FASTBEND-3D MT CONTROL

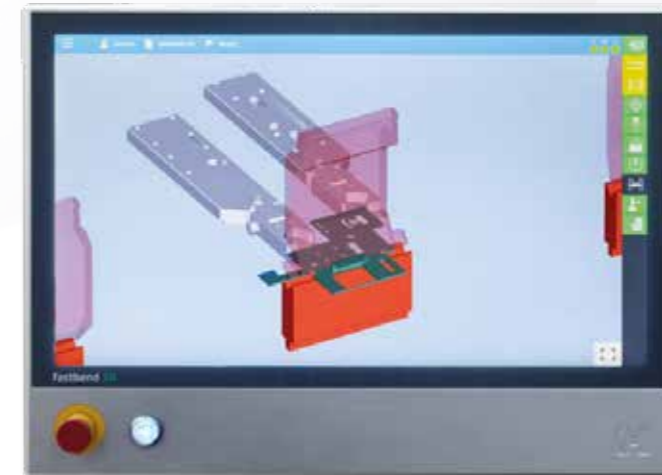

The FASTBEND-3D MT control has a 24" screen. It has all the features of the FASTBEND-2D MT Control. It allows you to directly utilize your STEP and IGS files on the machine's control panel.

After selecting your top tools, the FASTBEND-3D MT Control will automatically define the position of the different top tool sections, the bending sequence, and the positions of the axes for each step.

Advantages:

- You fully utilize your 3D files to program your machine in the blink of an eye.
- The machine can be programmed by personnel without any dedicated qualifications.

ADJUSTABLE HEIGHT (OPTIONAL)



In addition to the pivoting arm system already equipped on the machine, it can also be fitted with an adjustable height arm.

Advantage:

- Increases user comfort

Top tool clamping system

The EuroMaster-S can accommodate standard European type top tools known as 'ES'. This clamping system gives you access to a very wide selection of top tools. Thanks to its groove, the top tool is held in the clamp, even when loosened, to ensure the safety of the operator. The system allows for the clamping of standard length top tools of 835mm, 415mm, or sectionalized lengths.

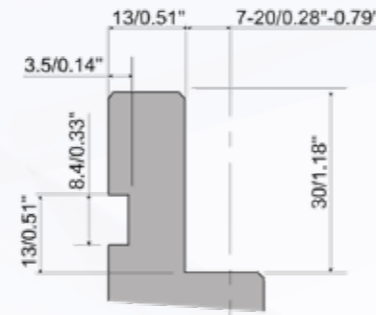

Standard equipment

QUICK CLAMPING SYSTEM



Thanks to its built-in lever, the system allows for quick tightening and loosening of the top tool. The evacuation of the top tools occurs on the side of the machine. The intermediate holders can have a height of 100mm, 120mm, or 150mm.

Advantages:

- Wide variety of top tools.
- Quick top tool change without an Allen key.

Optional equipment

RUBBER STRIP

A rubber band is added in the standard intermediary to increase the grip of the top tools sectionalized into small lengths.



ROL1 CLAMP3

Thanks to its ergonomic lever, the system allows for quick tightening and loosening of the top tool. The complete loosening of the system allows for the full removal of the clamp in record time, enabling the evacuation of top tools to the center of the machine on unoccupied intermediaries.



ROL200 MANUAL, PNEUMATIC, AND HYDRAULIC

The ROL200 allows for front evacuation of the top tools. This system exists in 3 different models. The manual version features a quarter-turn release as well as automatic clamping and releasing in pneumatic or hydraulic. The pneumatic and hydraulic systems are directly controlled by the FASTBEND MT Control.



ROLGRIP

Thanks to its ergonomic lever, the system allows for quick clamping and unclamping of the top tool without the use of an Allen key. The system allows for easy front evacuation of the top tool.

Optional equipment

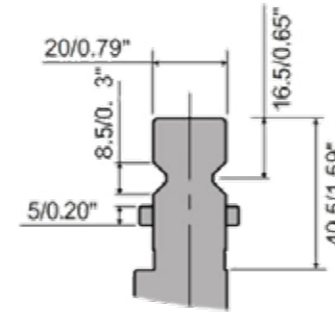

The 'ES' system can be replaced by a system called New standard 'NS' from Wila. The 'NS' system has no intermediates, and clamping can be done along the entire length of the machine. Once loosened, the top tool remains in the holder to ensure the operator's safety. The lightest top tools can be removed from the front using a click system. The standard lengths are: 515 mm, 255 mm, 200 mm or sectionalized lengths.

Advantages:

- Wide variety of top tools.
- Top tools can be positioned along the entire usable length.

MANUAL WILA CLAMPING SYSTEM

The WILA manual clamping system has a measuring scale to allow for precise positioning of the top tools. Clamping is done using an Allen key.



Advantage:

- Some tools can be removed vertically.

WILA HYDRAULIC CLAMPING SYSTEM

The hydraulic clamping system has the same advantages as manual clamping; the clamping is controlled by the CNC and is done in record time.



Advantage:

- Quick top tool change without an Allen key.

WILA HYDRAULIC CLAMPING SYSTEM WITH SMART TOP TOOL LOCATOR

LEDs are integrated in the top tool clamping system and indicate two types of information to the operator:

- The position where the top tools should be mounted during the adjustment phase.
- The position where the workpiece should be positioned during the bending phase.



Advantages:

- Reduced top tool change time.
- No more positioning errors of top tools.

Table

Standard equipment

EuroMaster-S has a 60mm groove to accommodate European Standard type bottom tools referred to as 'ES'. Two blocks of 15x15mm on either side facilitate clamping and allow, if removed, to extend the groove to 90mm for large opening matrices.

A 13 mm groove is also incorporated for clamping New Standard type matrices, referred to as 'NS'. The matrices are clamped using an Allen key. When the matrix is clamped, it is brought to a stop against the rear face and is directly centered. The top tools are of standard lengths 835mm, 415mm, or sectionalized.

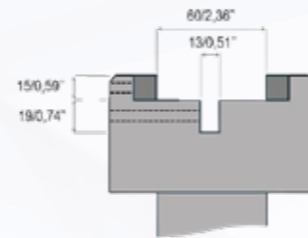

The drawing shows the 60mm base width and 13mm tang width of ES and NS bottom tools, respectively.



MOTORIZED CROWNING

The motorized Anti-Deflection table is directly linked to the control unit, and the choice of material, thickness, and length will automatically adjust the device.

Advantages:

- Gain in precision and quality.
- No set-up time.
- No alignment time thanks to the self-centering table.
- Compatibility with 60mm, 90mm and 13mm base dies.

Optional equipment for ES-type top tooling

ADDITIONAL CLAMPING HOLES

Additional clamping holes can be added to increase the clamping possibilities of the 'NS' bottom tools.



Optional equipment for NS-type tooling

The 'ES' system can be replaced by a system called New Standard 'NS' from Wila. This system has a groove for positioning mono-V bottom tools having a tang of 13 mm width. The standard lengths are: 500mm, 250mm, or fragmented lengths.



Advantages:

- No alignment time thanks to the self-centering table.
- Wide variety of bottom tools.

MANUAL WILA CLAMPING SYSTEM

The WILA manual clamping system has a measuring scale to allow for precise positioning of the top tools. Clamping is done using an Allen key.



Advantage:

- Narrow table width to increase free bending space.

WILA HYDRAULIC CLAMPING SYSTEM

The hydraulic clamping system offers the same advantages as manual clamping. On top of that the clamping is controlled by the CNC and is done in record time.



Advantage:

- Quick top tool clamping without Allen key.

WILA HYDRAULIC CLAMPING SYSTEM WITH SMART BOTTOM TOOL LOCATOR

LEDs are integrated in the bottom tool clamping system and indicate two types of information to the operator:

- The position where the top tools should be mounted during the adjustment phase.
- The position where the workpiece should be positioned during the bending phase.



Advantages:

- Reduced bottom tool change time.
- No more positioning errors of the bottom tools.

Backgauge

Standard equipment

BACKGAUGE X-R (2 AXES)

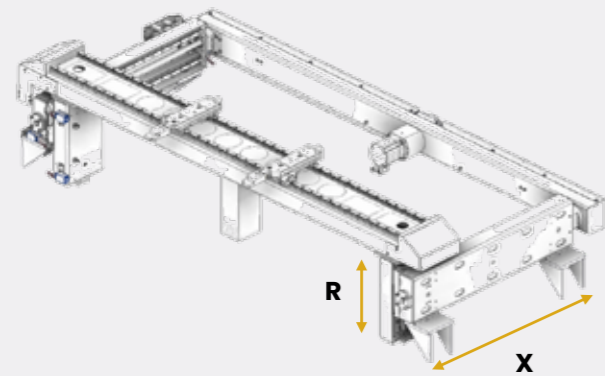

STROKES

Stroke X: 1000mm, speed 1000mm/s

Stroke R: 250mm, speed 250mm/s

The XR backgauge of the EuroMaster-S consists of a rigid beam and two fingers. The depth (X) and height (R) are motorized and controlled by the CNC. The fingers are manually adjustable along the length of the machine from the front and are equipped with 3 contact/support surfaces and are tiltable.

Advantages:

- Adjustment time for the fingers is significantly reduced.
- Possibility of having different finger positions within the same program, allowing you to bend a workpiece completely without having to shift the fingers.

Optional equipment

BACKGAUGE X-R-Z1-Z2 (4 AXES)

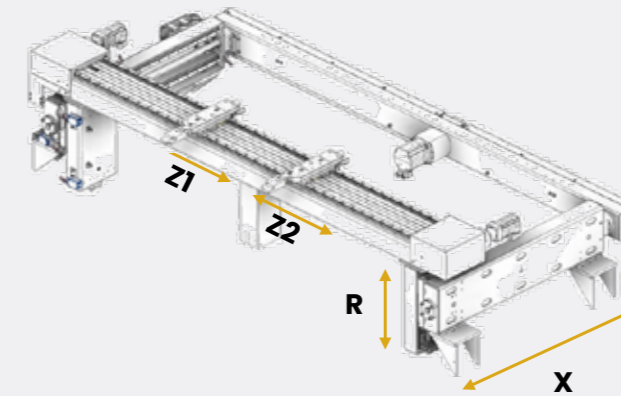

STROKES

X stroke: 1000mm, speed 1000mm/s

R stroke: 250mm, speed 250mm/s

Z stroke: Variable depending on the length of the machine

The backgauge X-R-Z1-Z2 has 4 motorized axes. In addition to the depth (X) and height (R), the two fingers move independently along the length axis (Z). They are named Z1 and Z2.

Advantages:

- There is no longer any set-up time for the backgauge.
- It is now possible to bend on tool sections of different lengths distributed along the length of the machine.

Optional equipment

ADDITIONAL FINGERS

Additional non-controlled fingers can be added to the machine to increase contact/support surfaces for bending long sheets. If the machine is configured with a 2-axis backgauge and 4 fingers (2 additional fingers), it is also possible to bend on two tool stations of different lengths.



Optional equipment

BACKGAUGE X-R-Z1-Z2-X3 (5 AXES)

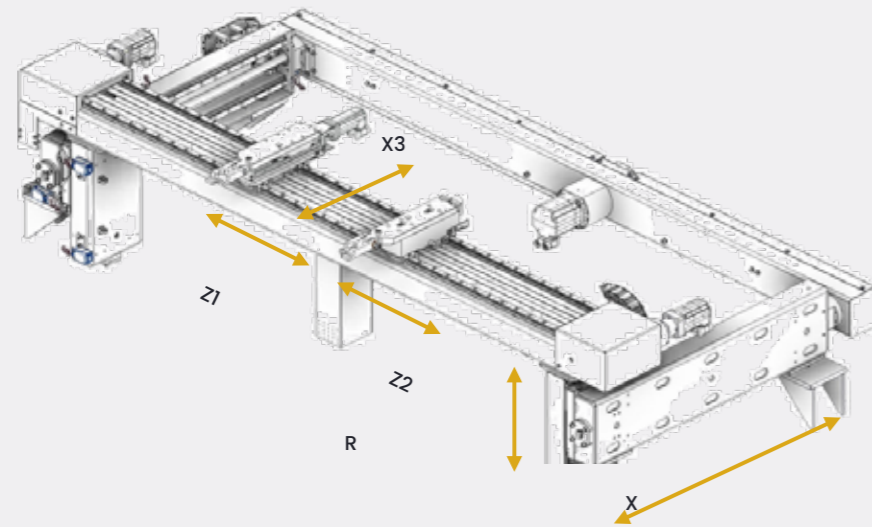

STROKES

Stroke X: 1000mm, speed 1000mm/s

Stroke R: 250mm, speed 250mm/s

Stroke Z: Variable depending on the length of the machine

Stroke X3: +50/-50mm

The backgauge X-R-Z1-Z2-X3 has 5 motorized axes. In addition to the depth (X) and height (R), the two fingers move independently along the length axis (Z). They are named Z1 and Z2. One of the two fingers has a motor to create an additional depth axis (X3). On this model of backgauge, the shape of the -beak- finger changes to facilitate a diagonal positioning.

Advantages:

- All the advantages of the 4-axes backgauge.
- The possibility to have a diagonal positioning of the fingers.

BACKGAUGE X1-X2-R1-R2-Z1-Z2 (6 AXES)

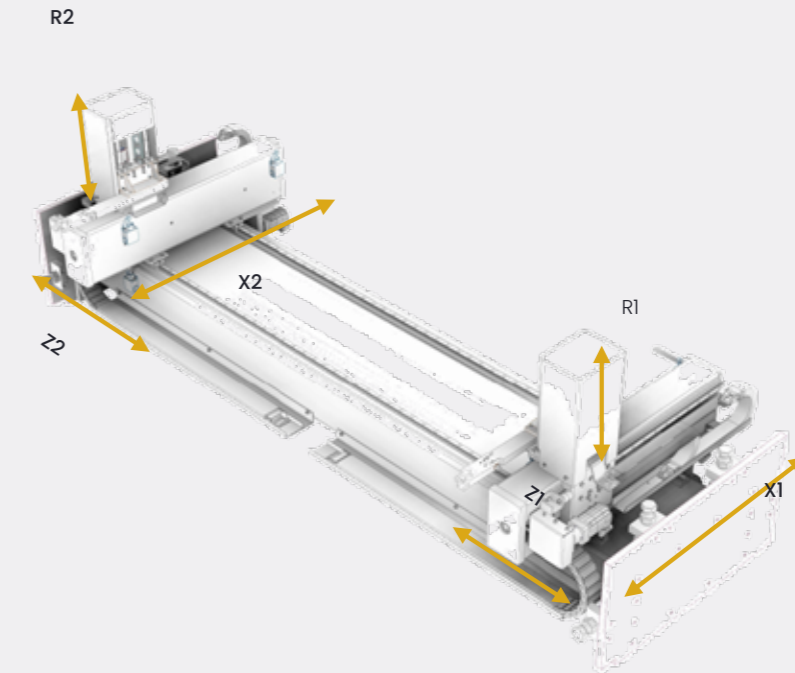

STROKES

Stroke X1-X2: 1000 mm

Stroke R1-R2: 135mm

Stroke Z: Variable depending on the length of the machine

The backgauge X1-X2-R1-R2-Z1-Z2 has 6 axes. Its design is completely different from other types of backgauges. In this configuration, the -beak- fingers move completely independent of each other.

Advantages:

- There is no longer any set-up time for the backgauge.
- It is now possible to bend on tool sections of different lengths distributed along the length of the machine.
- Ability to configure the backgauge fingers without positioning constraints

Safety

Standard equipment



3-POSITION SAFETY PEDAL

The safety pedal has 3 positions as well as an emergency stop. If the lowering pedal is fully pressed, the descent of the beam is interrupted.



SIDE DOOR

Two doors are located on either side of the machine. They ensure that no one is behind the machine during the bending phase. The doors open to facilitate the extraction of the top tools. An electromagnetic switch ensures that the door is properly closed during operation.



SAFETY LIGHT CURTAIN AT THE BACK

Light curtains facilitate access to the backgauge while ensuring safety during the bending phase. A simple push button allows you to reset the light curtain to resume bending.

Optional equipment



WIRELESS SAFETY PEDAL

The safety pedal has 3 positions as well as an emergency stop. If the lowering pedal is fully pressed, the descent of the beam is interrupted. The pedal consumes very little energy thanks to its solar charging system. It can operate for up to 1 month without recharging.

Current safety standards require the use of a non-contact barrier to work with a high descent speed of the beam. Optical modules are mounted on each side of the beam and stop the machine when an obstacle is detected.

LASERSAFE LZS-L6-HS



The LZS-L6-HS type laser is a system composed of two planar lasers. This efficient system allows for a mutation point at 6mm from the contact point of the sheet metal.



Optional equipment

LASERSAFE IRIS



The IRIS laser is the most efficient safety laser in the LazerSafe range. It allows for a mutation point at 0mm from the contact point of the sheet metal.



STANDARD LASER BRACKETS FOR IRIS (PLUS)



The supports allow the lasers to be raised to facilitate the removal of the top tools. A stop is present to maintain the adjustment position.

OPTIONAL MOTORIZED BRACKETS FOR IRIS (PLUS)



A motorized version is available to automate the adjustment and alignment with the top tool. The top tool unloading time is reduced as the supports rise automatically.

Angle measurement system

Optional equipment

LAZERSAFE IRIS PLUS ANGLE MEASUREMENT

The LazerSafe IRIS Plus has all the features of the optical safety laser IRIS. It also allows for the measurement of the bending angle. Once the angle is measured, the system sends the information to the control unit to correct the descent and thus achieve the desired bending.

The system has an operating mode to ensure precision without impacting productivity. This system is ideal for bending 2D workpieces from 1 to 4mm over a length of 3000mm.

Advantages:

- Since the system is incorporated into the optical safety system, it does not take up any space.
- Increased bending accuracy.
- Fully automatic. No need to make manual adjustments or corrections in the CNC.

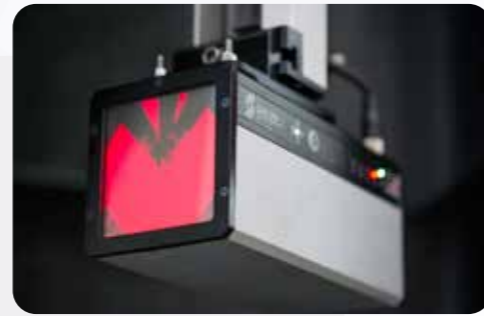

ALFA-F ANGLE MANUAL OR MOTORIZED MEASUREMENT

The ALFA-F system consists of 2 laser emitters and 2 cameras. It measures the bending angle in real-time and allows for direct application of corrections during the beam descent to achieve the desired angle.

The system can be moved manually, but it can also be motorized (optional). Optionally, a parking area can be installed at the end of the table. This system is ideal for 2D and 3D workpieces for sheets from 1 to 10mm with no length limit.

Advantages:

- Increased bending accuracy.
- Fully automatic. No need to make manual adjustments or corrections in the CNC.
- Ability to perform 2D control on workpieces.



Front supports

Standard equipment

FRONT SUPPORT ARMS

The front support arms, with a length of 750mm, facilitate the handling of workpieces. The support arms are movable along the entire length of the machine and can be easily adjusted in height. A T-slot allows for positioning of a tilting stop.

Advantages:

- Facilitates the handling of sheets and workpieces.
- Easy to move thanks to its guides and the locking screws and handles.



Optional equipment

SHEET FOLLOWING SYSTEM

This device is very useful when bending long & thin sheets. The arms are synchronized with the beam's descent to effectively support the sheet throughout the bending phase. Adjustment for width and height is easy and quick.



Advantages:

- Facilitates the handling of sheets and workpieces.
- Allows a single operator to handle sheets that typically require two operators or specific handling equipment..W

PARKING AREA FOR FRONT SUPPORT

Parking areas for standard supports or sheet following arms can be added on one or both sides of the table.

ADDITIONAL FRONT SUPPORT

Additional supports or sheet following arms can be added. They are particularly useful on machines of large lengths.

Offline software

Optional equipment

HACOBEND Pro 2D

The HACOBEND 2D software allows you to create 2D bending programs for your machine remotely on a computer.



Workpiece design

You choose the material, thickness, and bending length and simply draw the workpiece to be made point by point, indicating the various dimensions and angles. Assists in programming specific bends: stepped bends for radius, hemming, etc.

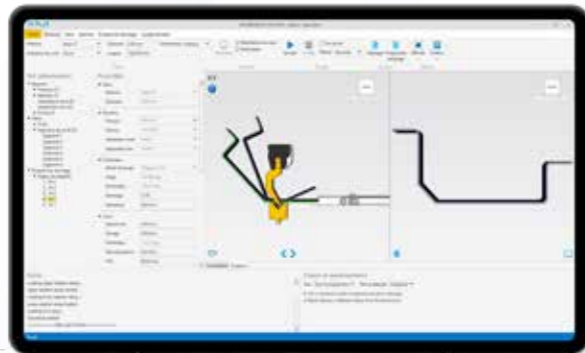

Program creation:

Top tools are suggested based on your usage habits, allowing you to modify them. The software automatically calculates a sequence of bends based on your workpiece. The sequence is calculated to avoid collisions and minimize workpiece reorientation. For each step of the bending sequence, the software programs the positions of the beam. Easily change the bending sequence and the position of the backgauge fingers.

Production :

You can open the program directly from your machine to start production.

Other features:

Automatic calculation of unfolding and DXF export feature.

Advantages:

- Masked time programming.
- Significantly reduced programming time.
- Make the machine accessible to an unskilled operator by programming in the design office.
- No need to calculate the unfolded sheet dimensions.
- Test the feasibility of bending before the production phase.

Optional equipment

HACOBEND Pro 3D

The HACOBEND Pro 3D software includes all the features of HACOBEND Pro 2D. The software has a section for 3D workpiece drawing and a section for importing 3D files.

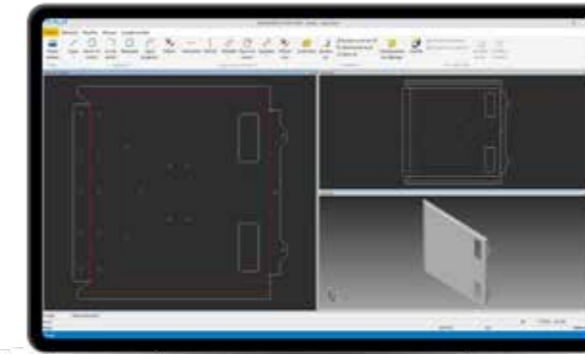

Workpiece design:

The software allows you to design workpieces in 3D, it includes all the workpiece drawing features with an additional function to directly create the joins between two bends.

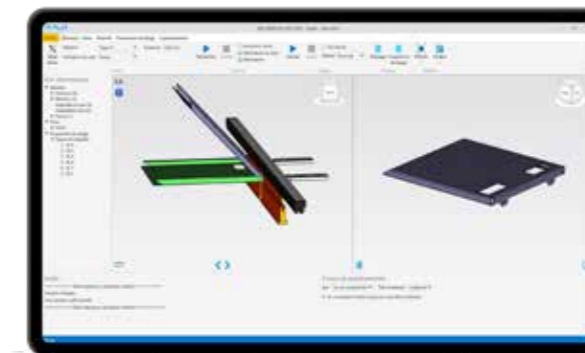

Program creation:

From your 3D drawing or imported 3D file, the software will automatically generate the program. It will pre-select the top tooling based on your bending habits and automatically establish the bending sequence and the position of the different axes. You will be able to simultaneously save the bending program and the DXF file with the actual unfolded sheet recalculated from the the tools used.

Production :

You can open the program directly from your machine to start production.

Other features:

Automatic calculation of unfolding and DXF export feature.

Advantages:

- Masked time programming.
- Significantly reduced programming time.
- Make the machine accessible to an unskilled operator by programming in the design office.
- No need to calculate the unfolded sheet dimensions.
- Test the feasibility of bending before the production phase.
- Ability to fully utilize your 3D files and avoid any new drawing or programming phase.

Technical specifications

	Basic European Standard (ES)			Option ES High Specs			Option New Standard (NS)			Option NS High Specs		
	opening	stroke	gap	opening	stroke	gap	opening	stroke	gap	opening	stroke	gap
	mm	mm	mm	mm	mm	mm	mm	mm	mm	mm	mm	mm
750 kN	520	270	400	620	370	400	440	270	400	540	370	400
1000 kN	520	270	400	620	370	400	440	270	400	540	370	400
1500 kN	520	270	400	620	370	400	440	270	400	540	370	400
2000 kN	520	270	400	620	370	400	440	270	400	540	370	400
2500 kN	520	270	400	620	370	400	440	270	400	540	370	400
3200 kN	620	420	400	-	-	-	540	420	400	-	-	-
4000 kN	620	420	400	-	-	-	540	420	400	-	-	-

European Standard

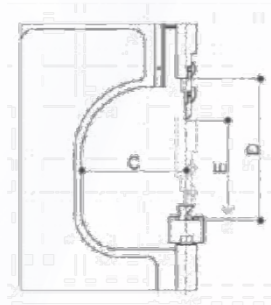

New Standard

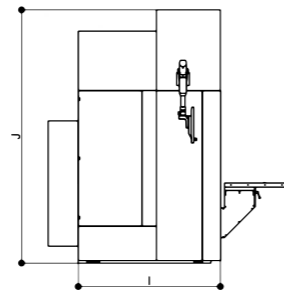
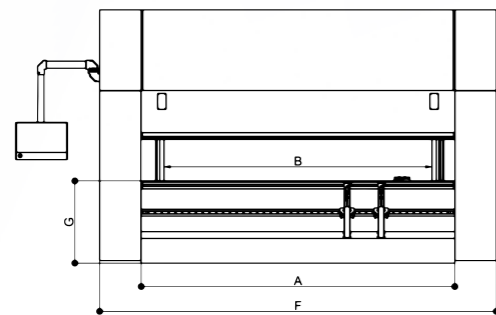
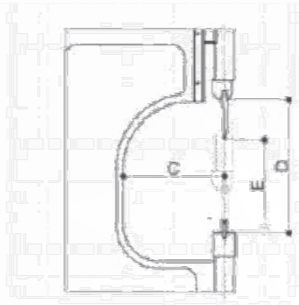

	Bending length [mm]	Capacity [kN]	Distance between housings [mm]	Table height [mm]	Fast approach speed [mm/s]	Max. bending speed [mm/s]	Fast Return speed [mm/s]	Motor power [kW]	Length [mm]	Width [mm]	Height [mm]	Weight [kg]
20075°	2100	750	1600	920	150	10	100	11	3090	1585	2735	5900
25075°	2600	750	2100	920	150	10	100	11	3590	1585	2735	7500
30075°	3100	750	2600	920	150	10	100	11	4090	1585	2735	8000
25100°	2600	1000	2100	920	200	10	125	11	3590	1585	2930	7500
30100°	3100	1000	2600	920	200	10	125	11	4090	1585	2930	9300
36100°	3650	1000	3150	920	200	10	125	11	4500	1585	2930	10500
40100°	4100	1000	3150	920	200	10	125	11	5090	1585	2930	10800
43100°	4300	1000	3750	920	200	10	125	11	5280	1585	2930	12100
25150°	2600	1500	2100	920	200	10	125	15	3590	1705	2930	8400
30150°	3100	1500	2600	920	200	10	125	15	4090	1705	2930	10100
36150°	3660	1500	3150	970	200	10	125	15	4635	1705	2930	11600
40150°	4100	1500	3150	970	200	10	125	15	5105	1705	2930	11900
43150°	4300	1500	3750	970	200	10	125	15	5280	1705	2930	13500
46150°	4600	1500	4100	950	200	10	125	15	5650	1760	2925	15500
25200°	2600	2000	2100	920	160	8	120	18.7	3590	1820	2920	10400
30200°	3100	2000	2600	920	160	8	120	18.7	4090	1820	3020	11200
36200°	3660	2000	3150	920	160	8	120	18.7	4500	1820	2920	12800
40200°	4100	2000	3150	920	160	8	120	18.7	5090	1820	2920	13700
43200°	4300	2000	3750	920	160	8	120	18.7	5280	1820	2920	16800
46200°	4600	2000	4100	945	200	8	120	18.7	5650	1870	3070	17500
30250°	3100	2500	2600	895	130	8	90	18.7	4090	2020	3020	13200
36250°	3660	2500	3150	895	130	8	90	18.7	4635	2020	3020	14800
40250°	4100	2500	3150	895	130	8	90	18.7	5090	2020	3020	16200
43250°	4300	2500	3750	895	130	8	90	18.7	5280	2020	3030	17100
50250°	5000	2500	4050	945	100	8	90	18.7	6240	2250	3170	24300
60250°	6000	2500	5050	1090	100	8	90	18.7	7240	2250	3360	31000
30320°	3100	3200	2600	895	100	8	95	22.5	4340	2210	3560	17500
36320°	3660	3200	3150	895	100	8	95	22.5	4900	2210	3560	20000
40320°	4100	3200	3150	895	100	8	95	22.5	5340	2210	3560	21500
43320°	4300	3200	3750	895	100	8	95	22.5	5540	2210	3560	23500
50320°	5000	3200	4050	940	100	8	95	22.5	6240	2210	3610	28000
60320°	6000	3200	5050	1095	100	8	95	22.5	7240	2210	3760	33000
30400°	3100	4000	2600	1045	90	7	60	37.5	4080	2570	4170	26500
36400°	3660	4000	3150	1045	90	7	60	37.5	4640	2570	4170	29500
40400°	4100	4000	3150	1045	90	7	60	37.5	5080	2570	4170	31500
43400°	4300	4000	3150	1045	90	7	60	37.5	5280	2570	4170	32500

A

B

G

F

I

J

HACO reserves the right to change any specifications without prior notice.
 ° EuroMaster-S models with built-in side doors
 * EuroMaster-S models with free-standing side doors, SynchroMaster style

HDSY Model

HDSY (Heavy Duty Synchro) press brakes are applied for heavy duty bending applications, requiring high tonnages and/or long bending lengths. These press brakes are p.e. required to bend thick plates of high tensile materials, requiring several hundreds of tons bending force per meter bending length.

HDSY press brakes are offered in a range of tonnages from 4000kN up to 20000kN and bending lengths from 3000mm up to 10000mm.



HDSY press brakes feature a rigid frame structure combined with advanced bending technology to allow high precision leveling and depth setting of the bending beam. Such, in combination with CNC controlled Anti-Deflection Table solutions, a consistent and precise bending angle is guaranteed over the full length.

Precise positioning of the workpiece is obtained by means of a wide selection of rigid CNC controlled back gauge configurations. Depending on your bending application, we advise required specifications and execution of your machine, as well as special top and bottom tooling to suit your needs.

Tandem or Tridem

HACO offers customised tandem and tridem solutions for applications where long bending lengths are combined with moderate tonnage requirements. In a tandem solution, two press brakes are combined in a flush floor set-up with double bending length and double tonnage, saving in foundation cost.



Tandem configurations are an alternative for single unit press brakes that often require high foundation costs. A tandem press brake combination can be operated as two single machines with two operators executing different jobs or combined in tandem operation with two operators forming one single large sheet metal part.

A tandem press brake set-up generally doesn't require a complicated and expensive foundation. Both machines are positioned next to each other, each as a single machine, but offering double length and double capacity. Tandem press brakes are executed with large gaps to allow full length workpieces with big flange lengths.



ADVANCED TECHNOLOGIES, SINCE 1965



Bending



Robotics



Cutting



Shearing

With decades of experience and leading technologies, we are known for our high-quality customized solutions for sheet metal fabrication and machining. Whether laser cutting, bending or shearing, at HACO we offer precision, quality and innovation.



Customized solutions



Made in EU



Global reach



Local focus

Find out how we can take your bending projects to the next level and view our extensive portfolio of success stories.



Machinery Masterminds

WWW.HACO.COM

HACO Offices:

HACO Belgium

Hogeschuurstraat 2
8850 Ardoorie
Belgium
+32 (0)51 26 52 00
info@haco.com

HACO France

Houssoye Business Park
é Laënnec Street
59930 La Chapelle D'Armentières
France
+33 3 20 10 30 40
commercial@haco.fr

HACO Slovakia

Ulica 1. Mája 1850
031 80 Liptovský Mikuláš
Slovakia

HACO USA

11629 N. Houston Rosslyn Rd.
Houston, TX 77086
USA
+1 281 445-3985
sales.tx@hacoatlantic.com

HACO Australia

16 Argong Chase
Cockburn Central WA 6164
Australia
+61 0 8 9414 7382
sales@hacoaustralia.com.au

HACO India

Plot No. 122A, Sector 6
MT, Bawal, Distt. Rewari Haryana,
India, 123501
+919996246805
sales@haco-india.com

This catalog is not a contractual document and is only for illustrative purposes. HACO reserves the right to modify any specifications within this catalog without prior notice.

EuroMaster-S/ 10.2024